

The Photographic Spectrograph (1.5 meter Bausch & Lomb)
Advanced Laboratory
Prepared by William S. Bickel

Introduction

Optical spectroscopy continues to be an important tool in science, technology and industry. Its importance lies in being able to separate light from various light sources - stars, plasmas, insects, lightning, galaxies, etc. - into the various component colors that make up the light. The various colors are spread out into a series of spectral lines called a spectrum. Various spectra are unique to their light sources whether they be atoms (any element in the periodic table), ions (of any atom), molecules, chemical and biological compounds. Each spectral line is identified by a number (wavelength) and can be used to identify the species in the source that emits it. Some elements - hydrogen for example - emits only a few lines in the visible. Other high Z atoms, molecules and compounds can emit thousands. The photographic spectrometer - called a spectrograph - that you will use in these experiments records the spectra on ordinary photographic film. More modern spectrographs use CCD's and computers to take the spectra - but the film will introduce the basic features of photospectroscopy that are common to all recording techniques.

The Spectrograph

The Bausch & Lomb 1.5 meter spectrograph used in these experiments is described in great detail in the Bausch & Lomb manual. You should look through this manual to learn the fine points of this particular instrument. For now we will describe the main features of any spectrograph-spectrometer-monochrometer system - regardless of what kind of spectral recording techniques are used.

Basic Spectrograph Optics

Basic spectrographic systems consist of 5 components: entrance slit, collimator lens, grating, camera lens and back focal plane. See Fig. 1

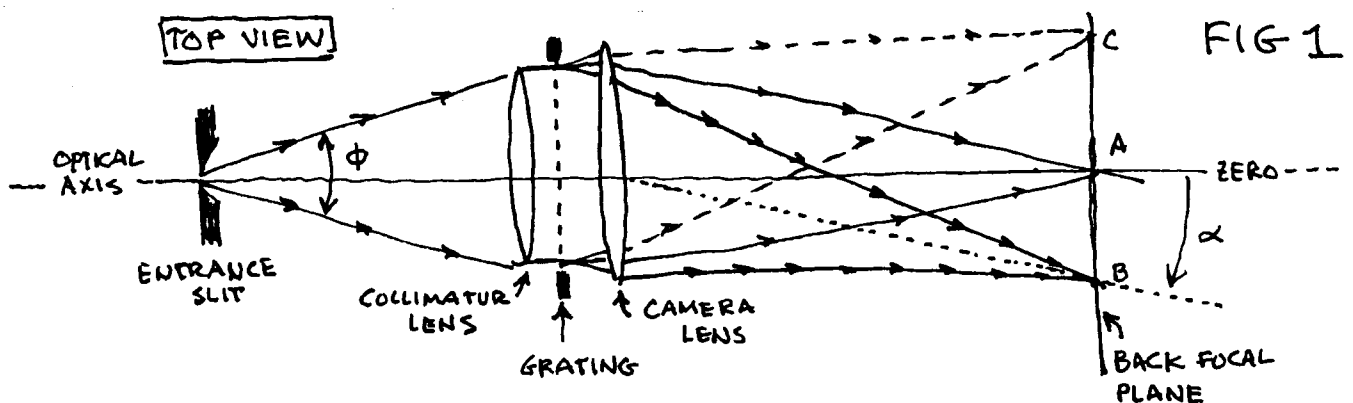

We will examine the function of each of these in detail.

1. The entrance slit with width w and height h is the "window" to the spectrograph. All light entering the spectrometer goes through the slit - whether it comes from a star, plasma, spectrum lamp, etc. The area of the slit is $A = lw$ and obviously as w increases so does A and therefore the amount of light entering the spectrograph.

2. The light from the source that enters the slit diverges and must hit and fill the collimator lens. The collimator lens has diameter D_{col} , area A_{col} and focal length f_{col} . The collimator lens is placed a distance f_{col} from the entrance slit. Therefore the diverging light from the entrance slit is rendered parallel by the lens and sent to the grating.

3. The grating accepts the parallel light from the collimator lens and diffracts it into various directions according to its various colors. This means that light of a particular color (wavelength) is sent into a particular direction β (diffracted through angle β). Just after the grating, in the space between the grating and camera lens we have bundles of parallel rays. Each bundle contains a single color. Some light goes straight through the transmission grating ($\beta = 0$) and is not diffracted at all. (We say this light goes into zero order). Any particular wavelength λ is diffracted through angle β on either side of zero order giving the first, second ----- m^{th} order spectrum. The grating diffracts light according to the formula:

$$m\lambda = nd(\sin \beta - \sin \alpha) \text{ where}$$

α = the angle of incidence on the grating

λ = wavelength

d = grating constant in mm/groove ($1/d = \#$ grooves/mm or lines/mm on grating)

β = angle of diffraction

m = order number ($m = 0, \pm 1, \pm 2, \pm 3$ -----)

n = refractive index of the medium the grating is in - usually air: $n = 1.000293 \approx 1$

If the spectrum lamp contained only one color λ the grating would create $2m+1$ bundles of parallel rays. One bundle goes straight through ($\beta = 0$, not diffracted). The others $2m$ bundles occur symmetrically on each side of zeroth order at $m = +1$ at $+\beta_1$; $m = +2$ at $+\beta_2$; ----- and $m = -1$ at $-\beta_1$; $m = -2$ at $-\beta_2$; ----- etc.

A single ray of light (of one color) hitting the grating would create the rays shown below in Fig. 2.

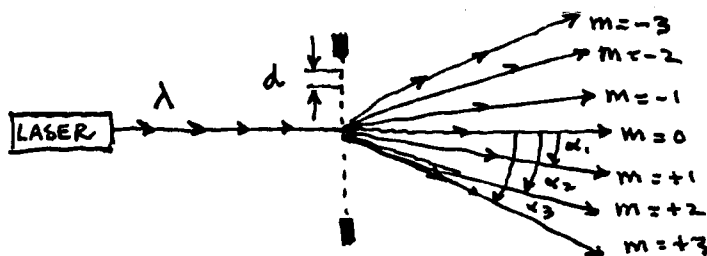

The Spectrum

Observe your spectrum lamp with the plastic grating that is attached to the side of the spectrograph. Hold it close to your eye and observe the zeroth order image and the colors that appear to the left and right of zeroth order.

Draw a ray diagram showing how your eye, grating and spectrum lamp form the colors. Note that the zeroth order image and the images in various colors are just images of the spectrum lamp! Now rotate the grating about all three axis and describe what you see.

4. The bundles of parallel rays, diffracted by the grating, are collected by the camera lens. The camera lens has a diameter D_{cam} , area A_{cam} and focal length f_{cam} . The bundles of rays, being parallel, are brought to focus at the focal point of the lens which is arranged to be on the focal plane (back focus, exit slit, CCD, etc.) located a distance f_{cam} from the camera lens.

5. The back focal plane is the place where the spectral lines are formed. The focal plane might be flat, or curved (a circular arc) or parabolic. Nevertheless the focal plane is carefully shaped so that all spectral lines that are diffracted through β come to focus on the plane. Here's where the strip of photographic film will be placed.

Summary

Lets review the role of each of the optical elements. Note that if the grating were removed, the optical system consisting of just two lenses on axis will perform a very simple function. Light diverging from a point on the center of the entrance slit is rendered parallel by the collimator lens and then brought to focus by the camera lens. These two lenses do nothing more than collect light from the slit and form an image of the slit at the back focus. See Fig. 3A and 3B below. To amplify this point, the two lenses could be replaced with a single lens with focal length f_c with $1/f_c = 1/f_{col} + 1/f_{cam}$. (Derive this formula)

Consider the SIDE VIEW of the slit-line optical system shown in Fig. 3A and 3B below:

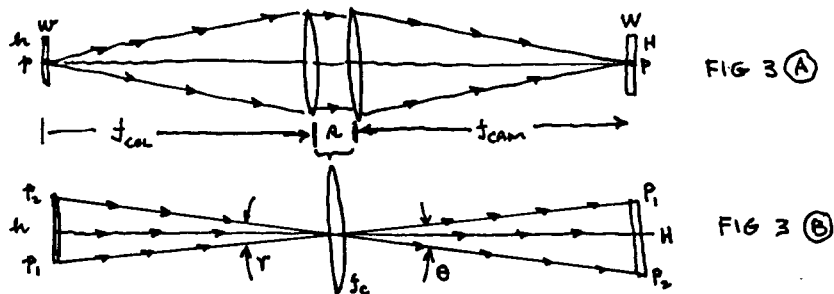

In Fig. 3B the two lenses of Fig. 3A have been replaced with a single lens. (i.e. let $s \rightarrow 0$ in Fig. 3A).

The perspective view of Fig. 4 below clearly shows that the spectral lines are nothing more than images of the entrance slit - formed in the spectral colors from the source.

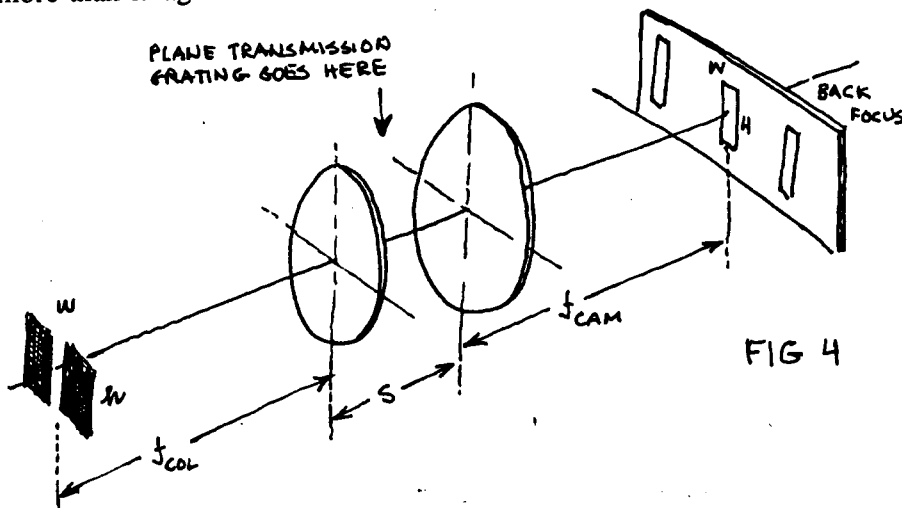

An interference filter, peaked to pass a single wavelength λ (say green), placed between the two lenses would produce a single green spectral line on the optical axis at the back focus.

Figure 5 below is a ray diagram of the TOP view of the spectrograph showing exactly how the spectral lines are formed.

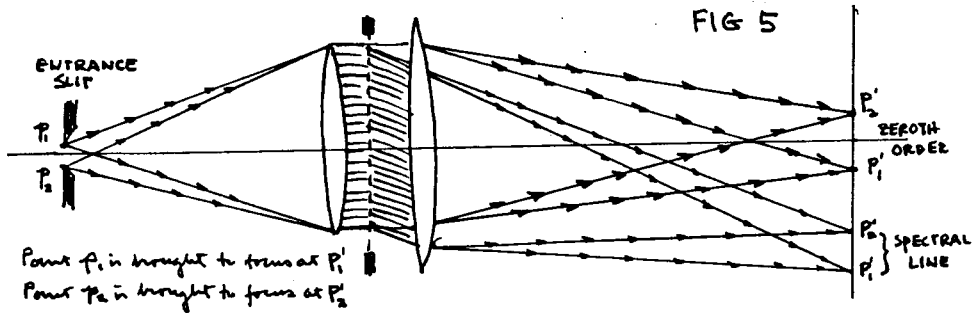

Now we introduce two important spectrographic parameters: angular and linear dispersion.

A. Angular dispersion of a grating

A grating spreads (separates, diffracts, disperses) light into various colors and it is important to know the angle between two different colors (λ_1 and λ_2). See Fig. 6 below.

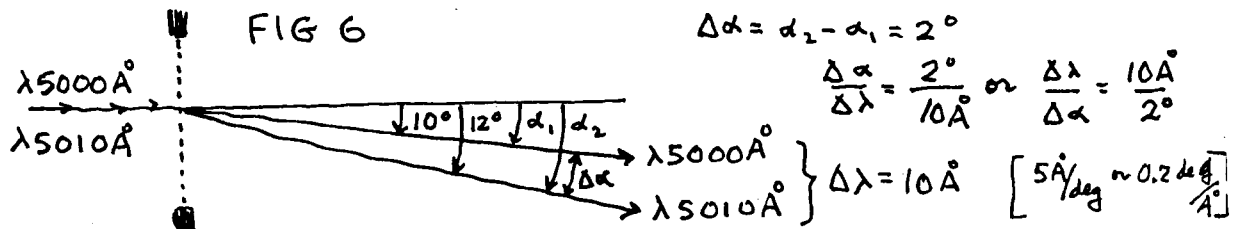

We have $m\lambda = d(\sin \beta - \sin \alpha)$. Let $\alpha = 0$ (normal illumination of the grating) then

$$m\lambda = d \sin \beta \quad \text{and} \quad m d\lambda = d \cos \beta d\beta \quad \text{giving}$$

$$d\beta/d\lambda = m/d \cos \beta = \text{angular dispersion (radians/\AAngstrom, deg/\AA)}$$

B. Linear dispersion (LD) of a spectrograph/spectrometer

The grating itself creates an angular dispersion - $\text{\AA}/\text{deg}$, $\text{\AA}/\text{radian}$ etc. The camera lens collects the bundles of parallel rays going into different directions and brings them to a focus at the back focus located a distance f_{cam} away from the camera lens. The lines occur at various positions x_i along the back focus. Their separation is Δx . The linear dispersion is simply $\Delta x/\Delta \lambda$ (or $\Delta \lambda/\Delta x$). See Fig 7 below.

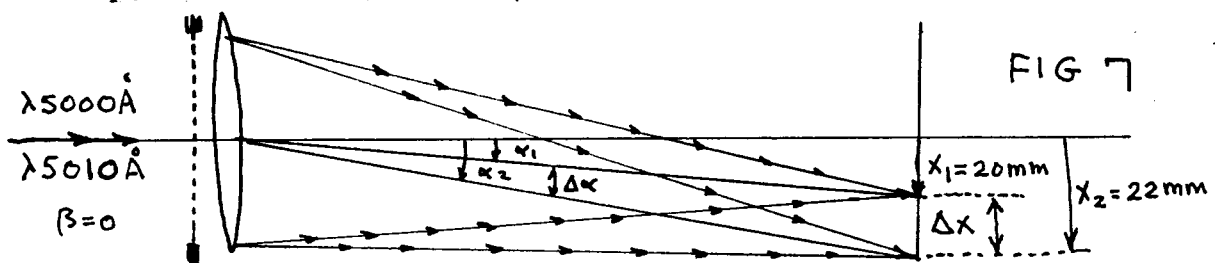

Note that this linear dispersion is an important property of any spectrograph/spectrometer/monochrometer. Even though it is dimensionless, its units make sense. They represent $\text{\AA}/\text{mm}$ (or $\text{mm}/\text{\AA}$) along the back focus.

In Fig 7 we have: $\frac{10\text{\AA}}{2\text{mm}}$ or $\frac{2\text{mm}}{10\text{\AA}}$ giving $\frac{5\text{\AA}}{\text{mm}}$ or $\frac{0.2\text{mm}}{\text{\AA}}$

For small $\Delta\beta$ we have $\Delta x = f_{\text{cam}} \Delta\beta$ so $\frac{\Delta x}{\Delta\lambda} = f_{\text{cam}} \frac{\Delta\beta}{\Delta\lambda} = f_{\text{cam}} [\text{Angular dispersion}]$

$\frac{\Delta x}{\Delta\lambda} = f_{\text{cam}} \left[\frac{m}{d \cos\alpha} \right]$ Note the units will be in $\frac{\text{mm}}{\text{\AA}}$

EXAMPLE: Let $f_{\text{cam}} = 1\text{meter}$ $m=1$ $d = \frac{1}{600}\text{mm}$ $\alpha \approx 0$ so $\cos\alpha = 1$ Then
 $\frac{\Delta x}{\Delta\lambda} = \frac{1\text{meter}(?)}{\frac{1}{600}\text{mm}(?)}$ $= \frac{600\text{meter}}{\text{mm}} \times \frac{1000\text{mm}}{\text{meter}} \times \frac{10^{-6}\text{mm}}{1\text{\AA}} = 6 \times 10^5 \times 10^{-6} \frac{\text{mm}}{\text{\AA}} = \begin{cases} 0.6\text{mm}/\text{\AA} \text{ or} \\ 1.66\text{\AA}/\text{mm} \end{cases}$

Use a HeNe laser ($\lambda 6328\text{\AA}$) (red) to measure the angular dispersion of the plastic grating. Shine the laser beam directly through the grating and form the diffraction pattern on a wall about $L = 2$ meters away. Show that the linear dispersion is proportional to L (or f_{cam}). Why don't we need a collimator or camera lens to do this? Rotate the grating about all three of its axis and explain what you see.

The above discussion reviews the basic optics of all spectrograph, spectrometer and monochrometer systems. The 1.5 meter Bausch & Lomb spectrograph works on the same principles described above except for the following modifications:

1. There is no collimator lens!
2. There is no camera lens! (How can we get focusing?)
3. The grating isn't illuminated with parallel light!
4. Light doesn't go through the grating! (Where does it go?)

ANSWER: The grating grooves in the Bausch & Lomb spectrograph are ruled on a concave mirror. This "concave grating" works exactly like the plane transmission grating - two lens system described above, even if it is not illuminated with exactly parallel light. (We say the light is essentially parallel)

Consider first the "concave aspect" of the grating which acts like a concave mirror. The ray diagram in Fig. 8 below describes the optics.

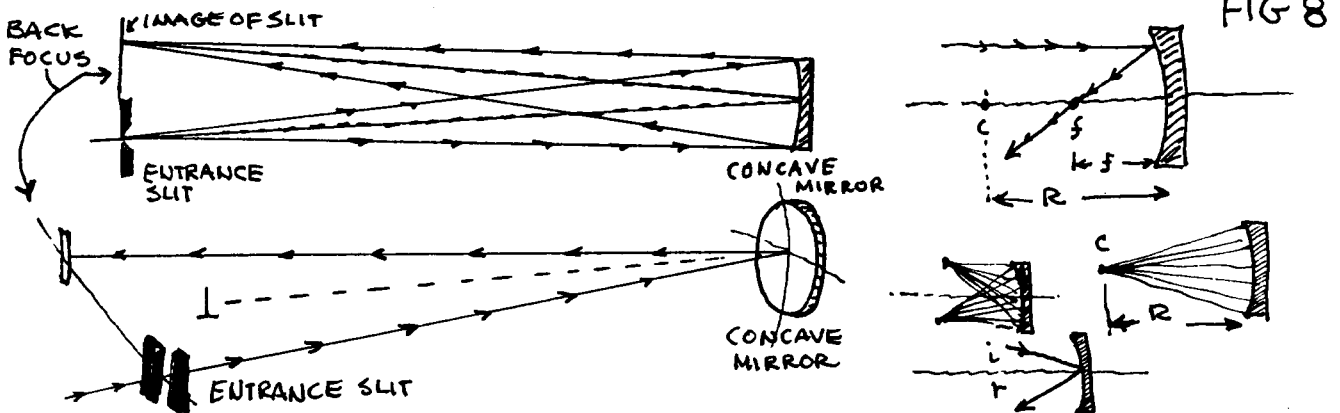

Now we rule grooves on the aluminum surface of the concave mirror to make a grating. The concave grating collects, reflects, diffracts and focuses - forming images on the entrance slit at various positions along the back focus according to the colors (wavelengths λ) that enter the slit. The concave grating acts as both a collimator and camera lens.

The ray diagram, in Fig. 9 below, describes the optics of a concave grating spectrograph.

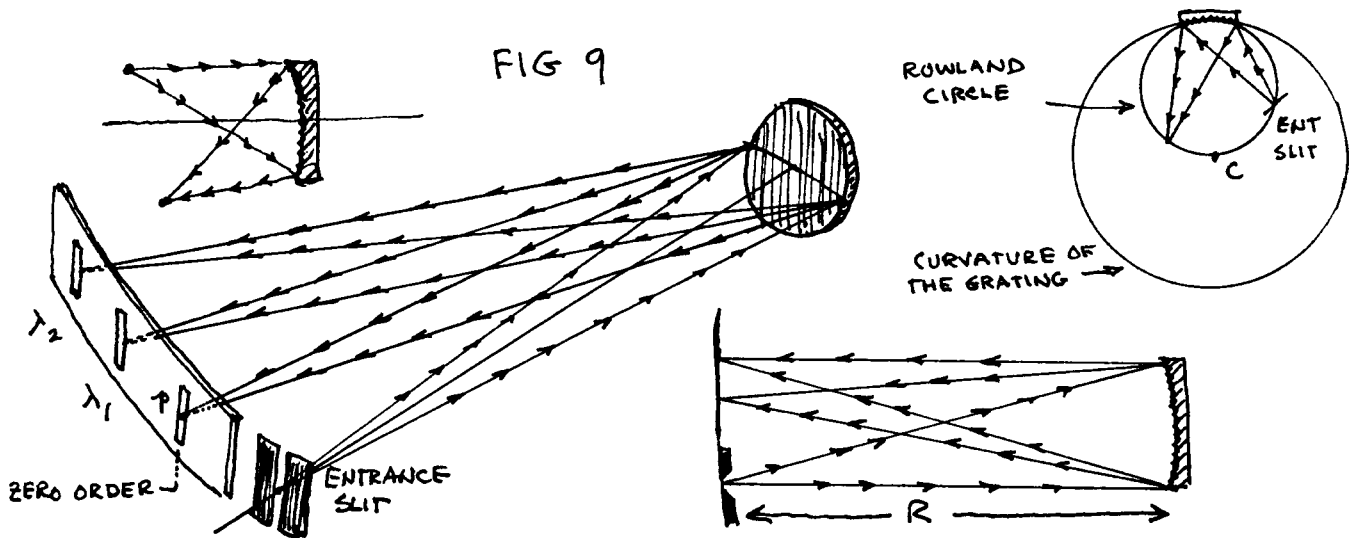

Note: A point p on the center of the entrance slit is focused to a point on the center of the spectral line. A point on the bottom of the entrance slit is focused to a point at the top of the spectral line. This "point to point" imaging of the slit to line (object to image) is called stigmatic imaging. It can be a very useful property of a spectrograph. Some spectrographs are astigmatic. This means that a point on the slit is imaged over the entire spectral line.

If the slit and back focus are located a distance R from the mirror the input and output paths are equal and the magnification M is $M = 1$. Suppose the slit were placed at $R/2$. Where would the spectral line be formed and what is its magnification?

We can remove the top of the spectrograph to see the optics inside. There are no moving parts. All alignments have been carefully made and all optical elements bolted tight to preserve the focus and prevent vibrations.

We see that an optical element, not yet discussed, is located between the entrance slit and grating. What is this? This stigmatic lens is essentially a very small angle prism (almost a plate of glass). Its purpose is to refract the light going to the grating slightly upwards so that the blue light of second order will be slightly displaced from the red light of first order at the back focus. This is done to separate orders and help identify 2nd order lines. This lens/prism element has no focusing properties. Therefore the original dimensions and location of slit/grating/back focus still hold.

The Experiments

1. Look through the plastic grating at a Black Body (continuous) source and a spectroscopic lamp and determine its angular dispersion.
Rotate the grating about all three axis - how does the image change?
Direct the beam from a HeNe laser through the grating. Again determine the angular dispersion, the grating constant (lines/mm), the length, width and area of the grating and the diameter of the laser beam.
Is there anything special about the photons that go undiffracted through the grating (into $m = 0$)? Do an experiment to check your answer.
2. Measure (or calculate) α , β , θ , ϕ , M , l , w , A , grating constant d , R_1 , R_2 , $d\Omega_{\text{slit}}$, $d\Omega_{\text{focus}}$ for the spectrograph.
What does the "1.5 meter" mean for this spectrograph?
Measure the width and heights of the three available slits. Note that the slits are formed by scratching a groove in the aluminum coating on the glass. What is a disadvantage of this construction?
Locate the direction and position of zeroth order inside the spectrograph..
3. Observe the entrance slit under a microscope and verify the widths and heights indicated on the slit holder.
Now use a laser beam and single slit diffraction ($m\lambda = w \sin \beta$) to verify the microscope measurements of slit widths. Which method is more accurate?
4. Discuss the role of the decker. How does it work? Why is it useful?
Would it work if the spectrograph were non-stigmatic?
How high (tall, long) should a spectral line be?
5. Measure the linear dispersion (LD) of the spectrograph, length of exposed area on film, the complete spectral range (left to right in first, second and third order).
Discuss the role of the fiducial light marker to mark the film.
Why is the back focus curved?
6. Illuminate the slit with a Black Body, H, He and Hg source. Adjust the source to get maximum intensity, form the spectra and observe the location, color and wavelength of the strongest lines at the back focus. Do these lines obey $m\lambda = d(\sin \beta - \sin \alpha)$?
Use the eyepiece to observe some intense known lines from your source and determine the linear dispersion.
Observe the shape of the lines as a function of slit width and decker location.
Remove the slit and decker entirely. What do the spectral lines look like?
7. Look at the grating (through the back focus) while illuminating it with the Geissler tube in various positions near the entrance slit. Is the grating full? How far to the left and right can the Geissler tube be moved while still illuminating the grating?
Insert the slit. Now how far can the tube be moved?
What is the largest distance the Geissler tube can be placed from the slit (on axis) and still

fill the grating with light?

Draw ray diagrams to show what is happening in all of these cases.

8. Photograph the spectra of H, He, and Hg, identify the lines and use them to get the linear dispersion and wavelength calibration.

Photograph the spectra of a Black Body and some other sources.

9. Discuss exposure time as a function of slit width for a spectral line source and for a continuous (Black Body) source.

Carefully examine the spectral lines on the film. What are their widths (in Ångstroms and mm) and shapes. Verify that the spectral lines are truly images of the entrance slit.

Discuss the energy, power, intensity, photons/sec entering the spectrometer.

Discuss the energy, power, intensity, photons/sec, photons/area in the spectral line.

Discuss the concepts of intensity/area, power/area, energy/time/area, photons/area, photons/time and plate - film darkening.

10. Use the dispersion curve to identify lines of unknown spectrum and identify the source.

11. Make black and white prints from the negative film strips. Mount the film strips and the black and white photographs on stiff cardboard and identify the strongest spectral lines.

Indicate the first and second order lines.

d:\teaching\spectrog.rph